

# AIRTAP HAND DRYER

## 473



110 V with IR sensor  
 Wall-mounted  
 Stainless Steel with black PVD coating  
 2-year warranty

AirTap features a minimalist, modern design in stainless steel with black PVD coating. The intelligent temperature control technology detects the room temperature and adjusts the heating element.

### Technical data

<b>Type</b>	<b>AIRTAP HAND DRYER</b> Prod. No.: 473  Touch-less warm-air hand dryer with IR sensor
<b>Dimension tap</b>	H: 1.96" x W: 1.96" x D: 8.66"
<b>Dimension motor</b>	H: 7.99" x W: 12.04" x D: 5.90"
<b>Material</b>	Stainless steel
<b>Drying cycle</b>	10-15 sec.
<b>Connection</b>	110 V, 50/60 Hz, Class I
<b>Total wattage</b>	600-1000 W
<b>Heating element</b>	100-500 W
<b>Motor</b>	500 W
<b>Noise level</b>	68,5-70,5 dBA
<b>Max. air capacity</b>	84-101 m/sec
<b>Max. air outlet temperature</b>	134.6 F
<b>Net weight</b>	12.89 lb
<b>IP rating</b>	IP35
<b>Tender text</b>	Touch-less hand dryer in stainless steel with black PVD coating for wall mounting. Infra-red sensor and electronic timer, drying cycle: 10-15 sec. IP35, 110 V, 50/60 Hz, 1000 W, Class I (earthed). 68.5-70.5 dBA. Net weight: 12.89 lb. H: 1.96" x W: 1.96" x D: 8.66"

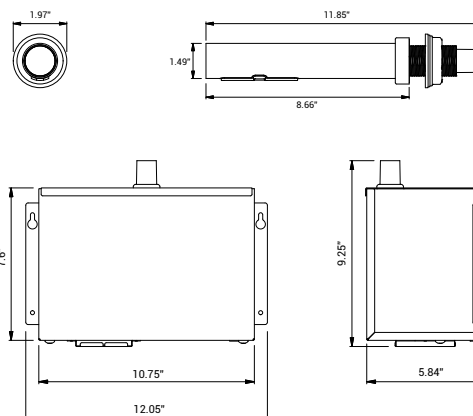

### Application

AirTap is a powerful hand dryer suitable for toilet rooms with a high visitor frequency. With its elegant slim design, the hand dryer is the perfect choice for toilet rooms with a behind-mirror solution. The DAN DRYER Tap range is an ideal build-in solution for construction projects and automatic hand wash stations.

### References

Shopping centres, restaurants, hotels, airports, sports facilities, schools and public institutions.

### Standard colour

Black PVD coating.

### Activation

Infrared sensor and electronic timer. Touchfree. Activation distance adjustable 5.11" (± 0.78"). Automatic stop after 60 seconds of continuous use.

### Motor type

Commutator motor with carbon brushes. 22,000-29,000 revolutions/min.

### Protection

Automatic thermal cut-out in both motor and heating element.

### Installation

Machine intended for wall mounting. Connection to fixed installation or via circuitbreaker. Installation must be carried out by a qualified electrician.

### Approval

